

ITEM NO.	PART NUMBER	DESCRIPTION	QTY
1	3-897-10100	MOUNTING BOLT, 10x1.5, 100mm	3
3	3-889-008P	WRENCH FOR 6IN & 8IN SCROLL CHUCK	1
4	3-886-308P	PINION FOR 8in SCROLL CHUCK	3
5	C-CK8-BDY3JFM	CHUCK BODY, 8IN	1
6	3-809-906P	FITTING, GREASE	1
7	3-887-308P	SCROLL PLATE FOR 8in CHUCK	1
8	3-888-910P	PINION SCREW FOR 8, 10 OR 12in CHUCK	3
9	C-CK8-COVER	PLATE, COVER, MACHINED	1
10	3-899-310P	SHCS, M8x1.25X16	3
11	3-897-608P	FINE ADJUSTMENT SCREW, M18x1 FOR 8in SET-TRU	4
12	C-CK8-MODULE	MODULE, SET-TRU, 8IN	1
2	3-891-308P	FULL OEM JAW REPLACEMENT SET, 8IN, 3-JAW	3
13	3-897-10035	MOUNTING BOLT, 10x1.5, 35mm	3

-CLICK ON LINK BELOW FOR REPLACEMENT PARTS-

WWW.TOOLMEX.COM

SELLING UNIT: EACH
 CHUCK TYPE: SCROLL
 CHUCK SIZE: 6IN
 BODY MATERIAL: FORGED STEEL
 NUMBER OF JAWS: 6
 JAW TYPE: 2 PIECES
 WEIGHT: 50 LBS
 MOUNT TYPE: FRONT
 GRIPPING FORCE: 3700 daN
 SPEED: 4000 RPM Max.

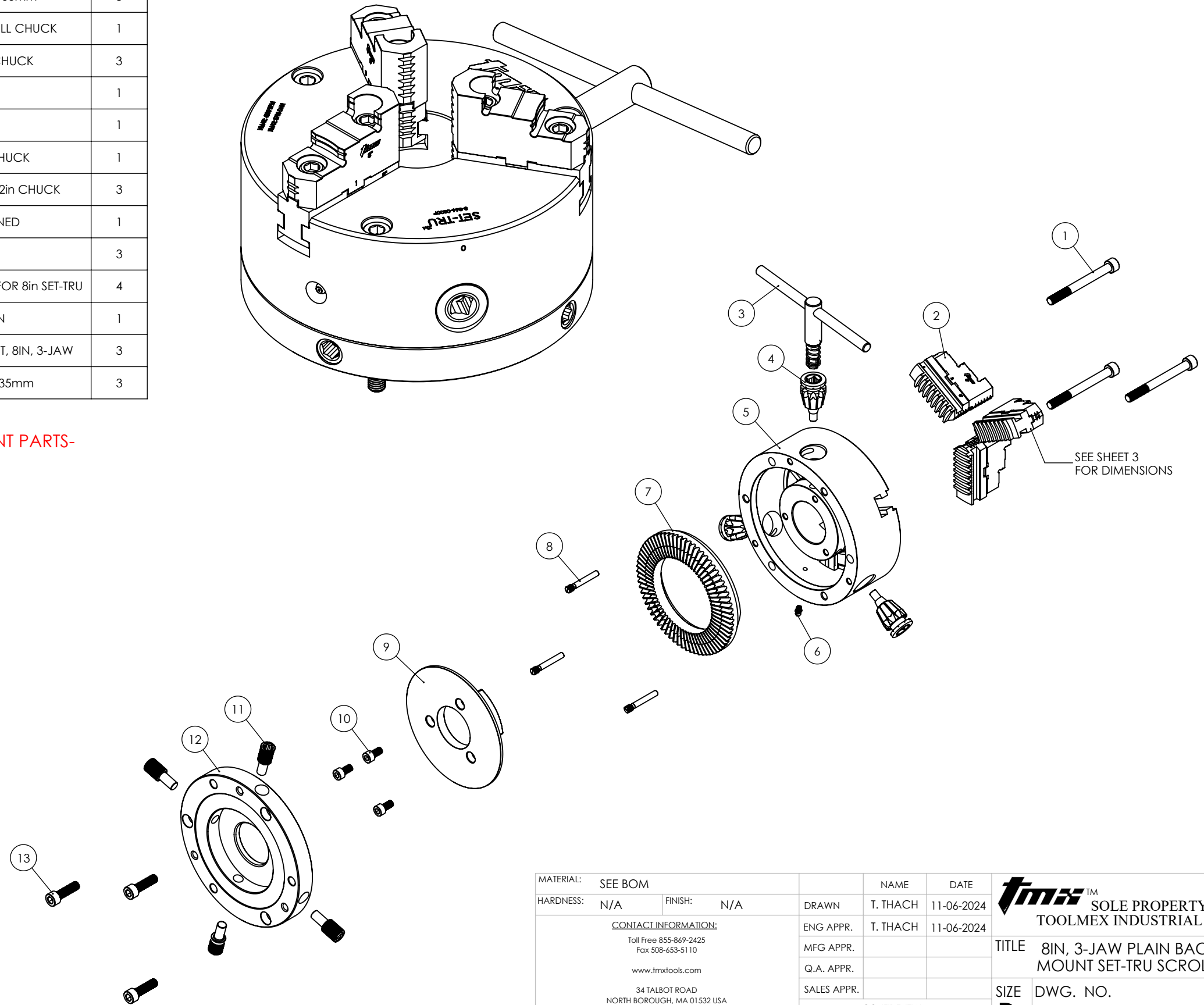

MATERIAL:	SEE BOM	NAME	T. THACH	DATE	11-06-2024
HARDNESS:	N/A	FINISH:	N/A	DRAWN	T. THACH
<u>CONTACT INFORMATION:</u> Toll Free 855-869-2425 Fax 508-653-5110 www.tmxtools.com 34 TALBOT ROAD NORTH BOROUGH, MA 01532 USA			ENG APPR.	T. THACH	11-06-2024
INTERPRET GEOMETRIC TOLERANCING PER: Y1999-2001			MFG APPR.		
 THIRD ANGLE PROJECTION			Q.A. APPR.		
CONFIDENTIAL THIS DRAWING AND THESE SPECIFICATIONS ARE THE SOLE PROPERTY OF TOOLMEX INDUSTRIAL SOLUTIONS, AND SHALL NOT BE REPRODUCED, OR COPIED IN PART OR AS A WHOLE WITHOUT THE EXPRESS WRITTEN PERMISSION OF TOOLMEX INDUSTRIAL SOLUTIONS IS PROHIBITED.			SALES APPR.		
Tmx ™ SOLE PROPERTY OF TOOLMEX INDUSTRIAL SOLUTIONS		TITLE	8IN, 3-JAW PLAIN BACK FRONT MOUNT SET-TRU SCROLL CHUCK		
SIZE	DWG. NO.	REV			
B	3-866-0800P	A			
UNITS IN MILLIMETER					
DO NOT SCALE DRAWING			SHEET 1 OF 3		

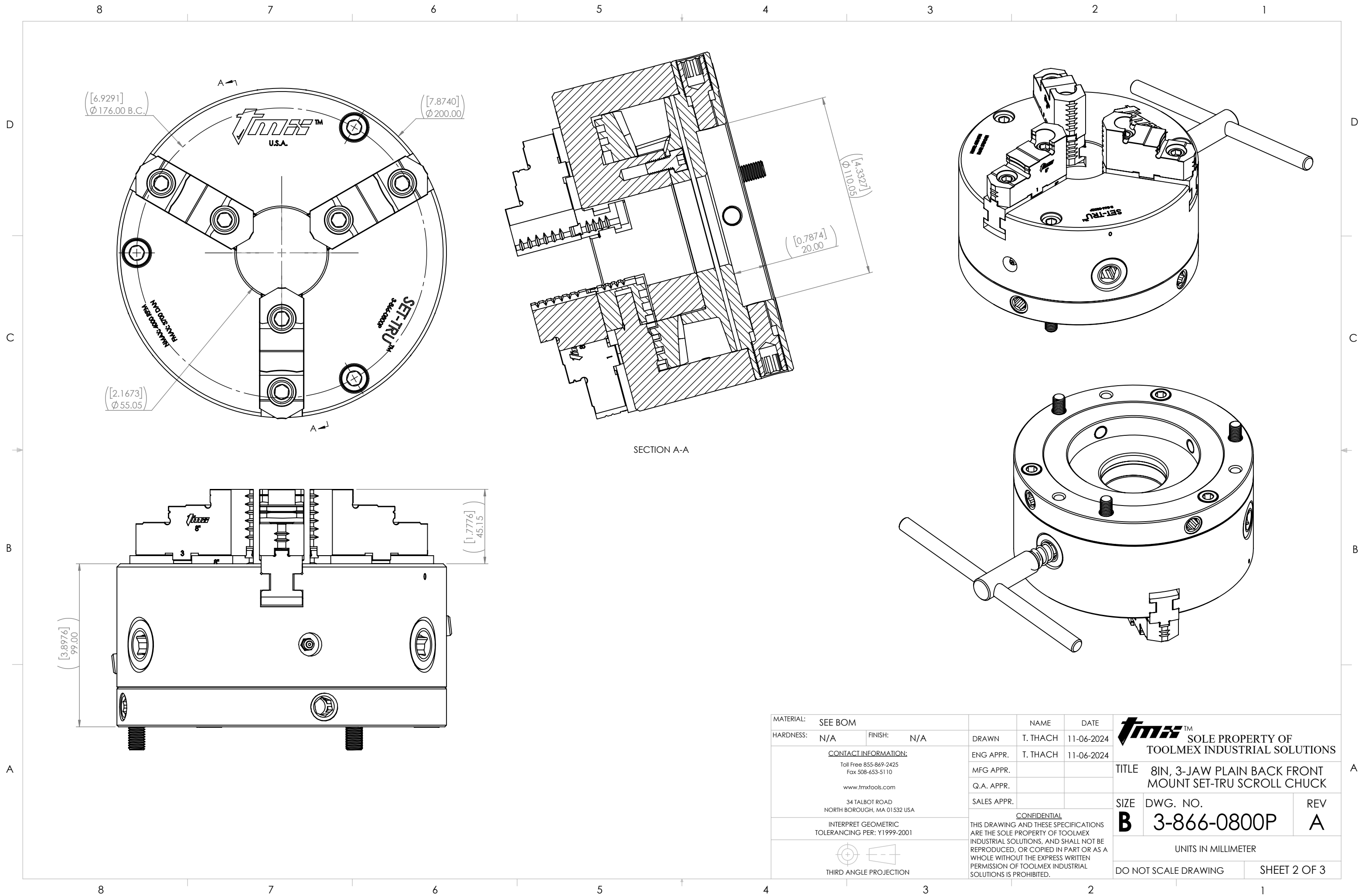

MATERIAL:	SEE BOM	NAME:	T. THACH	DATE:	11-06-2024
HARDNESS:	N/A	FINISH:	N/A	DRAWN:	T. THACH
<p>CONTACT INFORMATION: Toll Free 855-869-2425 Fax 508-653-5110 www.tmxtools.com 34 TALBOT ROAD NORTH BOROUGH, MA 01532 USA</p>			ENG APPR.	T. THACH	11-06-2024
			MFG APPR.		
			Q.A. APPR.		
			SALES APPR.		
<p>INTERPRET GEOMETRIC TOLERANCING PER: Y1999-2001</p>			<p>CONFIDENTIAL THIS DRAWING AND THESE SPECIFICATIONS ARE THE SOLE PROPERTY OF TOOLMEX INDUSTRIAL SOLUTIONS, AND SHALL NOT BE REPRODUCED, OR COPIED IN PART OR AS A WHOLE WITHOUT THE EXPRESS WRITTEN PERMISSION OF TOOLMEX INDUSTRIAL SOLUTIONS IS PROHIBITED.</p>		
<p>THIRD ANGLE PROJECTION</p>			<p>SOLE PROPERTY OF TOOLMEX INDUSTRIAL SOLUTIONS</p>		
			<p>TITLE: 8IN, 3-JAW PLAIN BACK FRONT MOUNT SET-TRU SCROLL CHUCK</p>		
			<p>SIZE: DWG. NO. B 3-866-0800P</p>	<p>REV: A</p>	
			<p>UNITS IN MILLIMETER</p>		
			<p>DO NOT SCALE DRAWING</p>		<p>SHEET 2 OF 3</p>

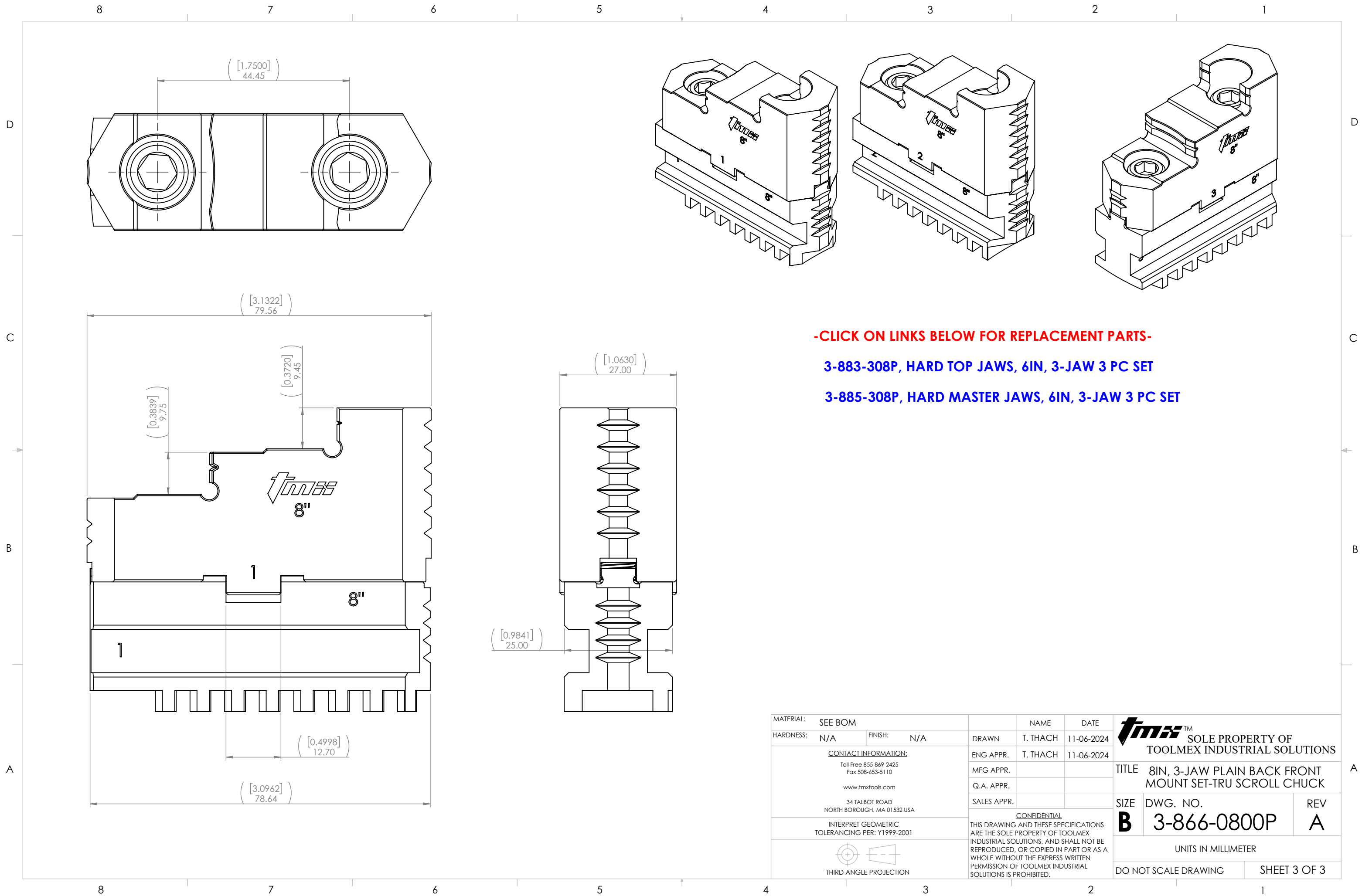

-CLICK ON LINKS BELOW FOR REPLACEMENT PARTS-

3-883-308P, HARD TOP JAWS, 6IN, 3-JAW 3 PC SET

3-885-308P, HARD MASTER JAWS, 6IN, 3-JAW 3 PC SET

MATERIAL:	SEE BOM	NAME	T. THACH	DATE	11-06-2024
HARDNESS:	N/A	FINISH:	N/A	DRAWN	T. THACH
<p>CONTACT INFORMATION: Toll Free 855-869-2425 Fax 508-653-5110 www.tmxtools.com 34 TALBOT ROAD NORTH BOROUGH, MA 01532 USA</p> <p>INTERPRET GEOMETRIC TOLERANCING PER: Y1999-2001</p> <p>THIRD ANGLE PROJECTION</p>			ENG APPR.	T. THACH	11-06-2024
			MFG APPR.		
			Q.A. APPR.		
			SALES APPR.		
<p>CONFIDENTIAL THIS DRAWING AND THESE SPECIFICATIONS ARE THE SOLE PROPERTY OF TOOLMEX INDUSTRIAL SOLUTIONS, AND SHALL NOT BE REPRODUCED, OR COPIED IN PART OR AS A WHOLE WITHOUT THE EXPRESS WRITTEN PERMISSION OF TOOLMEX INDUSTRIAL SOLUTIONS IS PROHIBITED.</p>			<p>TOOLMEX™ SOLE PROPERTY OF TOOLMEX INDUSTRIAL SOLUTIONS</p>		
<p>TITLE 8IN, 3-JAW PLAIN BACK FRONT MOUNT SET-TRU SCROLL CHUCK</p>		SIZE	DWG. NO.	REV	
		B	3-866-0800P	A	
<p>UNITS IN MILLIMETER</p>					
DO NOT SCALE DRAWING			SHEET 3 OF 3		